



KC11 SERIES Sealless Non-Metallic Centrifugal Pumps

Installation & Maintenance Instructions

ASSEMBLY

WARNING: Magnet field hazard. This pump contains powerful rare earth magnets. When the pump is disassembled (not connected to a motor) and the magnets are exposed, these magnets produce powerful magnetic fields. Individuals with cardiac pacemakers, implanted defibrillator, other electronic medical devices, metallic prosthetic heart valves, internal wound clips (from surgery), metallic prosthetic devices or sickle cell anemia must not handle or be in the proximity of the magnets contained inside the pump. Consult a health care provider for specific recommendations before working with this pump.

Unpack pump from carton and check for shipping damage.

ATEX COMPLIANT PUMPS

All assembly, installation, and maintenance instructions are the same as standard pumps with the exceptions noted on page 4 under "Additional Information for the Use of ATEX Compliant Pumps."

PUMPS WITH MOTORS

Remove shipping caps and inserts from suction and discharge, and proceed to installation instructions.

PUMPS WITHOUT MOTORS - 145TC

1. Remove pump end assembly from box.
2. Remove two Phillips pan head screws (item 7) and hex nuts (item 9) from impeller housing. Then remove wet end assembly from motor adapter.
3. Remove hardware package from box.
4. Install motor adapter (item 4) onto motor. Place 3/8" flat washers (item 15) between the motor adapter and the motor. Flat washers must be aligned with motor adapter mounting holes. Align motor adapter with motor rabbet and secure with socket head cap screws (item 10) and lock washers (item 11). See figure 6.
5. Continue to step 5 of ASSEMBLY - PUMPS WITHOUT MOTORS - ALL OTHER MOTORS.

ALL OTHER MOTORS

1. Remove pump end assembly from box.
- CAUTION:** Strong magnets present. Keep metal objects and metallic chips/particles away from pump components.
2. Remove two Phillips pan head screws (item 7) and hex nuts (item 9) from impeller housing, and remove wet end assembly from motor adapter.
3. Remove hardware package from box.
4. Install motor adapter (item 4) onto motor and secure with socket head cap screws (item 10) and lock washers (item 11). Refer to Figure 6.
5. Coat the motor shaft with anti-seize compound. Slide drive

magnet assembly (item 5) onto motor shaft keeping shaft key in place. Installation dimension from front of drive magnet assembly to face of motor adapter is $.180 \pm .010$ inches ($4.57 \text{ mm} \pm .25 \text{ mm}$). Tighten 2 set screws (item 5A) with a 3/16" "T" handle Allen wrench to 228 in-lbs (25.8 N-m). A spacing tool is available for setting proper dimension (p/n A103188). See Figure 1.

IMPORTANT: Verify the tightness of the set screws in the drive magnet assembly prior to operation.

6. Install the wet end assembly by grasping the discharge with

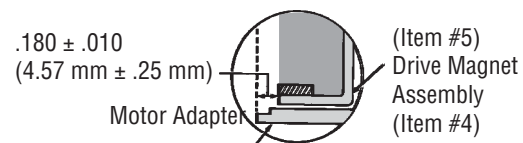

Figure 1

your right hand the "fins" (marked 3 and 5 in figure 2) with your left hand. Carefully align the wet end with the motor adapter and allow the magnets to pull it into place.

- WARNING:** Components can slam together from strong magnets. Do not allow fingers to get between the wet end and the motor adapter.

Align mounting holes and install 5 Phillips pan head screws (item 7) and hex nuts (item 9). Hand tighten screws to 30 in-lbs. (3.34 N-m) of torque using the pattern shown in figure 2.

Note: Plastic pumps will expand and contract with temperature so periodically check and hand tighten the Phillips head pan screws.

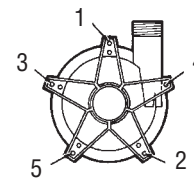

Figure 2

7. Remove the two-piece shipping plug and insert from the suction of the housing after the pump has been placed into the system and just before you attach the piping. Keep the shipping plug for use when disassembling the pump. Always use the shipping plug when assembling or disassembling the wet end to protect the internal parts.
8. Install pump into system according to installation instructions below.

INSTALLATION

MOUNTING

Motor or base plate should be securely fastened.

PIPING

1. Support piping near pump to eliminate any strain on pump casings.
2. To minimize head loss from friction:
 - a. Increase pipe size by 1 diameter.
 - b. Use minimal number of pipe bends.
3. Keep bends a minimum of 10 pipe diameters from suction and discharge.
4. Position pump as close to liquid source as possible.
5. Maintain a flooded suction.
6. Ensure that piping does not leak.
7. Install valves on suction and discharge lines (a minimum of 10 pipe diameters from pump).
8. For units in a suction lift system, install appropriate piping in the discharge to allow priming of pump.
9. The suction valve should be fully open to avoid restricting suction flow.

IMPORTANT: To protect the pump if prime is lost, use one of the following: (1) pressure switch on the discharge; (2) vacuum switch on the suction; (3) a motor minder to monitor motor current.

10. When pumping liquids which may solidify or crystallize, a flush system should be added to the piping. See Figure 3. Install water inlet and outlet valves as shown.

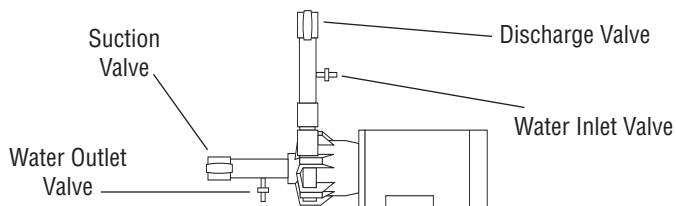

Figure 3

ELECTRICAL

Install motor according to NEC requirements and local electrical codes.

IMPORTANT: To verify correct motor rotation: (1) Install pump into system. (2) Fully open suction and discharge valves. (3) Allow fluid to flow into the pump. Do not allow pump to run dry (PTFE and ceramic bushings cannot be run dry without damage to pump components). (4) Jog motor (allow it to run for one or two seconds) and observe rotation of motor fan. Correct rotation is clockwise as viewed from motor fan. Refer to directional arrow on pump.

OPERATION

FLOODED SUCTION SYSTEM

1. Fully open suction and discharge valves.
2. Start the pump and check liquid flow. If no flow, see troubleshooting section.
3. Adjust flow rate and pressure by regulating discharge valve. Do not attempt to adjust flow with the suction valve.

SUCTION LIFT SYSTEM

1. Fully open suction and discharge valves.
2. Prime system by filling priming chamber and suction line with liquid to be pumped. Allow time for trapped air to work its way out.
3. Start the pump and check liquid flow. If no flow, see troubleshooting section.
4. Adjust flow rate and pressure by regulating discharge valve. Do not attempt to adjust flow with the suction valve.

FLUSH SYSTEMS

1. Fully close suction and discharge valves.
2. Connect water supply to water inlet valve.
3. Connect drain hose to water outlet valve.
4. Open inlet and outlet valves and flush system until pump is clean (approximately 5 minutes).

MAINTENANCE

DISASSEMBLY

1. Disconnect power. Remove electrical wiring and mounting bolts to floor or base plate.
 2. Close suction and discharge valves, and disconnect piping.
 3. Install the two-piece shipping plug into the suction of the housing. Remove the 5 Phillips pan head screws and hex nuts (items 7 and 9).
 4. Securely clamp or hold motor in place. Remove wet end by gripping the discharge with your right hand while gripping the two fins marked 3 and 5 in figure 2. With a tight grip, pull the wet end straight out of the motor adapter using one quick motion.
- ⚠ WARNING:** Components can slam together from strong magnets. Keep fingers away from area between housing and motor adapter.
5. To disassemble wet end, remove the 4 Phillips head screws (item 13).
 6. Remove impeller housing (item 1) from barrier (item 3), and pull out the impeller assembly (item 2). Remove o-ring (item 6). To remove drive magnet assembly (item 5), insert a 3/16" hex wrench in the access hole on motor adapter top and loosen the 2 set screws (item 5A). Remove the drive assembly from the motor shaft.

To remove the drive magnet assembly, use a hook-type puller through the 1/2" hole or a yoke-type puller through the 3/8" threaded holes. Pull the drive by pushing off of the end of the motor's shaft. Always coat the motor shaft with an anti-seize compound prior to reinstalling.

- ⚠ CAUTION:** Strong magnets present. Keep metal objects and metallic chips/particles away from pump components.

EXAMINATION

1. Check impeller drive bushing (item 2A), thrust ring (item 2B), ceramic thrust rings and shaft for cracks, chips, scoring or excess wear (See Figure 4). Replace as required.
2. Check for loose magnets on drive assembly or rubbed areas on impeller or barrier assemblies. Contact your distributor or FTI Technical Service if a problem is found.

Figure 4

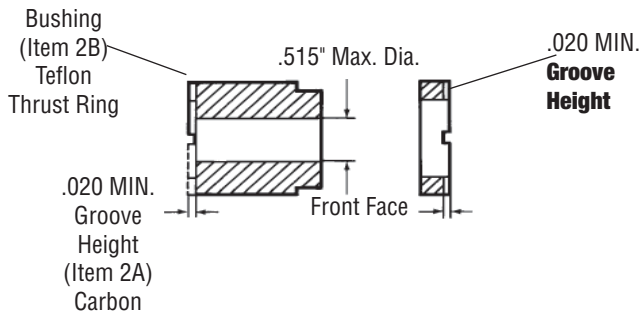

BUSHING AND THRUST RING REPLACEMENT

1. To remove the bushing, place the impeller assembly (item 2) in an arbor press. Insert a 3/4" diameter plastic or wood shaft through the eye of the impeller and press bushing out. Refer to Figure 5.
2. To replace the bushing, place the top of the impeller on an arbor press with the thrust ring (item 2B) face down. Insert the front of the bushing (see figure 4) into the center of the impeller, aligning the flat on the bushing with the flat in the impeller. Press into

Figure 5

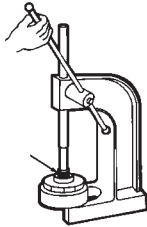

place until the rear of the bushing (the slotted end) is .855 below the bottom of the impeller. An installation tool (P/N M102392) is available to aid in proper installation.

3. The impeller thrust ring (item #2B) can be removed from the impeller body (item #2) by gently pulling the ring from the impeller cover.
4. To replace the thrust ring, align the flat on the ring (grooved side up) with the flat on inside of the impeller assembly (item 2), and press into place.

Note: Protect thrust ring face with wood or plastic and avoid tilting of the ring.

REASSEMBLY

WET END SUBASSEMBLY

1. Install o-ring (item 6) onto lip of barrier assembly (item 3).
2. Make sure impeller assembly is free of metal chips. Position impeller assembly (item 2) onto shaft and lower into barrier.
3. Lubricate the o-ring with a chemically compatible lubricant and install impeller housing (item 1) onto barrier, making sure to align matching bosses on barrier with recesses in impeller housing. Install 4 Phillips head screws and tighten carefully, do not over-tighten.
4. For reassembly of wet end to motor, refer to assembly section, page 1, steps 6- 8.

SAFETY PRECAUTIONS FOR ATEX PUMPS

⚠ WARNING: The pump must be checked for leaks on a regular basis. If leaks are noticed, the pump must be repaired or replaced immediately.

⚠ WARNING: The pump must be cleaned on a regular basis to avoid dust build up greater than 5 mm.

⚠ CAUTION: Proper o-ring material must be chosen based on the fluid being pumped. Improper material selection could lead to swelling and a possible source of leaks. This is the responsibility of the end user.

⚠ WARNING: ATEX pumps must use a power monitor, flow switch, pressure switch or similar device to help protect against dry running, closed discharge valve and decoupling. Any of these conditions could lead to a rise in surface temperature of the pump.

TEMPERATURE CLASSIFICATION

The surface temperatures of the KC ATEX Series pumps depend upon the temperature of the fluid being pumped. The chart below lists different fluid temperatures and the corresponding pump surface temperatures.

Fluid Temperature	Maximum Surface Temperature	Temperature Class	Maximum Allowable Surface Temperature
80°F (27°C)	122°F (50°C)	T6	85°C
185°F (85°C)	192°F (89°C)	T4	135°C
220°F (104°C)	248°F (120°C)	T3	200°C

TROUBLESHOOTING

NO DISCHARGE

1. Pump not primed.
2. Discharge head too high.
3. Suction lift too high. Insufficient NPSH.
4. Closed valve.
5. Viscosity too high (magnets uncoupled).

INSUFFICIENT DISCHARGE

1. Air leaks in suction piping.
2. Discharge head higher than anticipated.
3. Suction lift too high or insufficient NPSH. Check also for clogged suction line or foot valve.
4. Foot valve too small.
5. Foot valve or suction opening not submerged enough.

INSUFFICIENT PRESSURE

1. Air or gasses in liquid.
2. Impeller diameter too small.
3. Discharge head higher than anticipated.

LEAK AT IMPELLER HOUSING

1. O-ring pinched or chemically attacked. Replace with new o-ring.
2. Phillips pan head screws improperly or overtightened. Install according to assembly instructions.
3. Check motor adapter for cracks.
4. Total overall pressure too high. Do not exceed 35 psi inlet and outlet pressure.

LOSS OF PRIME

1. Leaking suction line.
2. Suction lift too high or insufficient NPSH.
3. Air or gasses in liquid.
4. Foreign matter in impeller.
5. Leaking foot valve.

TROUBLESHOOTING continued on page 5.

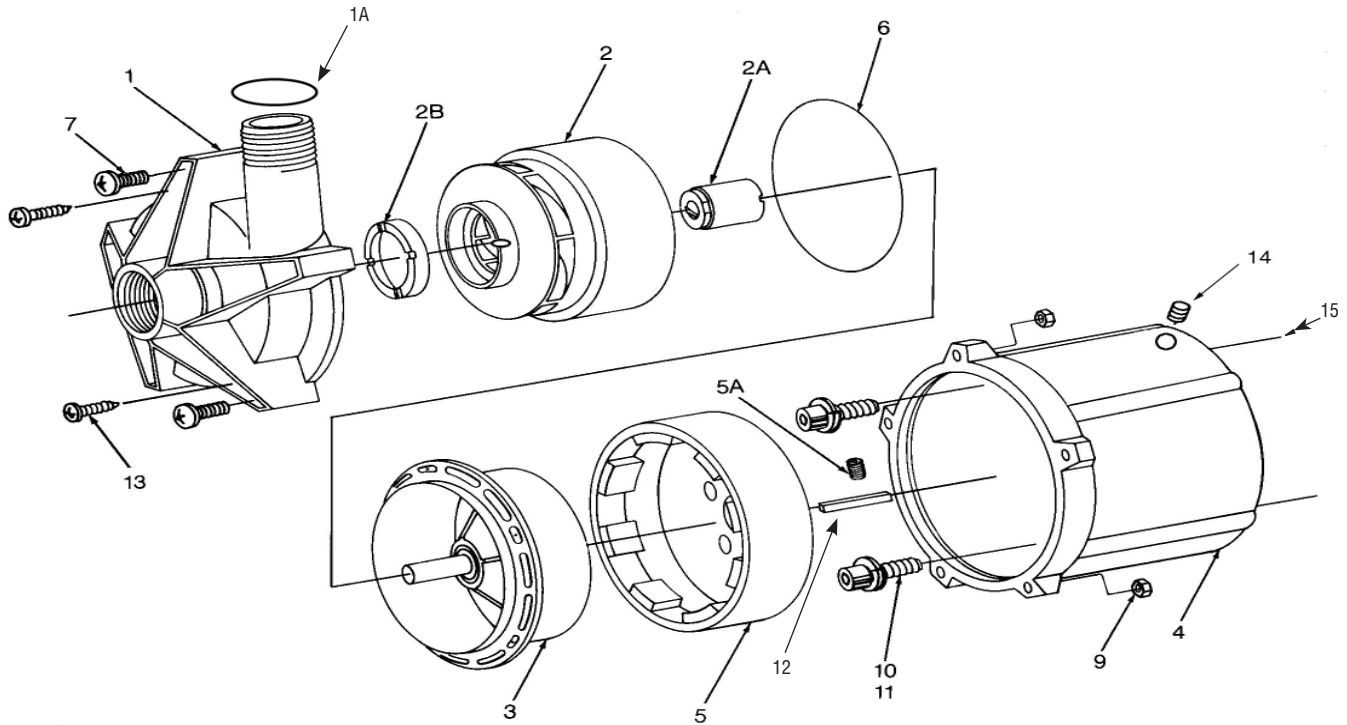

Item	Qty	Description	Part Number	
			Polypropylene	PVDF/ATEX
1	1	Housing Assy - NPT w/ ceramic thrust ring	A101014-1	A101014-2
		Housing Assy - BSP w/ ceramic thrust ring	A101014-4	A101014-5
1A	1	FKM Discharge O-ring (BSP only)	J103128	
		EPDM Discharge O-ring (BSP only)	J103129	
2	1	4-1/2" Impeller w/ carbon bushing	A101928	A101936
		4" Impeller w/ carbon bushing	A101929	A101937
		3-1/2" Impeller w/ carbon bushing	A101930	A101938
		3" Impeller w/ carbon bushing	A101931	A101939
		4-1/2" Impeller w/ PTFE bushing	A101932	A101940
		4" Impeller w/ PTFE bushing	A101933	A101941
		3-1/2" Impeller w/ PTFE bushing	A101934	A101942
		3" Impeller w/ PTFE bushing	A101935	A101943
		4-1/2" Impeller w/ ceramic bushing	A103106	A103110
		4" Impeller w/ ceramic bushing	A103107	A103111
		3-1/2" Impeller w/ ceramic bushing	A103108	A103112
2A	1	Carbon Bushing only	J100977	
		PTFE Bushing only (optional)	106386	
		Ceramic Bushing only (optional)	106386-2	
2B	1	PTFE Thrust Ring only	J101606	
3	1	Barrier w/ Ceramic Shaft & Thrust Ring)	A101008-1	A101008-2
4	1	Motor Adapter U.S.	M101629-1	
		Motor Adapter IEC 80 Frame	M101629-2	
		Motor Adapter IEC 80 Frame ATEX	M101629-4	
		Motor Adapter IEC 90 Frame	M101629-3	
		Motor Adapter IEC 90 Frame ATEX	M101629-5	

Item	Qty	Description	Part Number
			PP, PVDF, & ATEX
5	1	Drive Magnet Assy 56C Motors	A101019-1
		Drive Magnet Assy 145TC Motors	A101019-2
		Drive Magnet Assy 80 Frame Motors	A101019-3
		Drive Magnet Assy 90 Frame Motors	A101019-4
5A	2	Set Screw	J101084
6	1	Housing O-Ring FKM	J102774
		Housing O-Ring EPDM	J102775
7	5	Phillips Pan Head Screws	J100998
9	5	Hex Nut	J100321
10	4	Socket Head Cap Screw U.S.	J101000
		Socket Head Cap Screw IEC 80 frame	J101080
		Socket Head Cap Screw IEC 90 frame	J101081
11	4	Lock Washers U.S. 145TC	J100128
		Lock Washers Metric 80 frame	J100672
		Lock Washers Metric 90 frame	J101083
12	1	Shaft Key US 3/16 (ATEX N/A)	M101708
		Shaft Key IEC 80 frame 6mm	M101647
		Shaft Key IEC 90 frame 8mm	M101749
13	4	Phillips Head Screws	J101020
14	1	Plug for Access Hole	J102878
15	4	3/8 SS Flat Washer 145TC only	J100128

Note: For Wet End Only (incl. items 1, 2, 3, 6 & 13) SEE PRICE SHEET

TROUBLESHOOTING (continued from page 3)

EXCESSIVE POWER CONSUMPTION

1. Head lower than rating. Pumps too much liquid.
2. Specific gravity or viscosity of liquid pumped is too high or higher than that defined in application.

VIBRATION

1. Excess bearing wear.
2. Drive magnet uncoupled.
3. Loose magnet.
4. Pump Cavitating

WARRANTY

Finish Thompson, Inc (manufacturer) warrants this pump product to be free of defects in materials and workmanship for a period of one year from date of purchase by original purchaser. If a warranted defect, which is determined by manufacturer's inspection, occurs within this period, it will be repaired or replaced at the manufacturer's option, provided (1) the product is submitted with proof of purchase date and (2) transportation charges are prepaid to the manufacturer. Liability under this warranty is expressly limited to repairing or replacing the product or parts thereof and is in lieu of any other warranties, either expressed or implied. This warranty does apply only to normal wear of the product or components. This warranty does not apply to products or parts broken due to, in whole or in part, accident, overload, abuse, chemical attack, tampering, or alteration. The warranty does not apply to any other equipment used or purchased in combination with this product.

The manufacturer accepts no responsibility for product damage or personal injuries sustained when the product is modified in any way. If this warranty does not apply, the purchaser shall bear all cost for labor, material and transportation.

Manufacturer shall not be liable for incidental or consequential damages including, but not limited to, process down time, transportation costs, costs associated with replacement or substitution products, labor costs, product installation or removal costs, or loss of profit. In any and all events, manufacturer's liability shall not exceed the purchase price of the product and/or accessories.

CHEMICAL REACTION DISCLAIMER

The user must exercise primary responsibility in selecting the product's materials of construction, which are compatible with the fluid(s) that come(s) in contact with the product. The user may consult Finish Thompson, Inc. (manufacturer) and a manufacturer's representative/distributor agent to seek a recommendation of the product's material of construction that offers the optimum available chemical compatibility.

However neither manufacturer nor agent shall be liable for product damage or failure, injuries, or any other damage or loss arising out of a reaction, interaction or any chemical effect that occurs between the materials of the product's construction and fluids that come into contact with the product's internals.

ORDERING OF SPARE PARTS

Spare parts can be ordered from your local distributor. Always refer to pump model number to avoid error.

OTHER FINISH THOMPSON PRODUCTS

Drum Transfer Pumps are available in sanitary construction, stainless steel, polypropylene, PVDF and CPVC. Flows to 40 gpm, discharge heads to 300 feet and viscosities to 100,000 cP.

Portable Mixers for turbine mixing and blending handle viscosities to 1,000 cP with gentle, non-vortexing circulation. Available in 316 stainless steel construction.

Centrifugal Pumps in polypropylene, PVDF, and 316 SS are offered in mag drive sealless or mechanical seal models. Pumps are capable of 330 gpm, up to 325 feet discharge head, and 220°F (104°C) maximum. For more information, contact Finish Thompson Inc. or see our web site at www.finishthompson.com.

Call our toll free Technical Service Hot line, 1-800-888-3743, if you have any questions regarding product operation or repair.



FINISH THOMPSON INC.

921 Greengarden Road • Erie, PA 16501-1591 U.S.A.
Ph 814-455-4478 • Fax 814-455-8518
Email fti@finishthompson.com • www.finishthompson.com

J102315, Rev. 18, 5/13/11 Literature I.D.
No. FT97-6420

