



AC6 & AC8 HORIZONTAL SERIES Sealed Metallic Centrifugal Pumps Installation and Maintenance Instructions

ASSEMBLY

PUMPS WITH MOTORS

1. No assembly required. Unpack the pump and motor and examine for any signs of shipping damage. If damage is detected, save the packaging and notify the carrier immediately.
2. Proceed to the "Installation" section of these instructions.

PUMPS WITHOUT MOTORS

Note: Do not remove shipping plug located in suction port of the pump until the pump is completely assembled onto the motor.

1. Unpack the pump and examine for any signs of shipping damage. If damage is detected, save the packaging and notify the carrier immediately.

Special Note: AC6HJS 90 frame only -

- a. Using the hardware provided (items 9, 10, & 11), bolt the motor adapter (item 8) to the motor.
 - b. Attach the mounting plate (item 14) to the motor adapter using the hardware provided (items 12 & 13).
 - c. Proceed to page 2 of the Installation and Maintenance Manual and follow steps 1 through 9 under "Reassembly."
2. Insert key into motor keyway. Visually determine key location in pump end. Align keyway slots on motor shaft and pump impeller sleeve. Slide pump assembly over the motor shaft until the pump motor adapter (item 8) is completely seated over the motor rabbet. The drain slot should always be on the bottom. Install 4 bolts with flat washers and lock washers (items 9,10,11) into the motor face. Securely tighten bolts.
 3. Lubricate o-ring of self-sealing bolt (item 6) with suitable, compatible lubricant. Insert self-sealing bolt through shipping plug and into the eye of the impeller using a 9/16" deep well socket. Insert a screwdriver into the motor fan to prevent motor shaft from rotating. Tighten the bolt to 12-ft lbs.
 4. Remove the shipping plug from the suction port.
 5. Rotate the motor fan by hand and check for impeller rubbing. If the impeller rubs, verify that the self-sealing bolt is properly installed.
 6. Proceed to the "Installation" section of these instructions.

INSTALLATION

MOUNTING

Motor or base plate must be securely fastened.

PIPING TO AND FROM THE PUMP:

- Always support the piping near the pump to minimize stress and strain on the pump's casing.

- Minimize frictional losses by increasing the suction piping size by one diameter.
- Use a minimal number of bends on suction piping, keeping any bends a minimum of ten pipe diameters from the pump.
- Install a shut off valve on the suction line and a flow control valve in the discharge line. Place the valves a minimum of ten pipe diameters from the pump.
- Ensure that the piping is leak free.
- Position the pump as close to the liquid source as possible.
- Maintain a flooded suction at all times or prime the pump and maintain prime at all times.

CAUTION: Do not run the pump dry. This pump should never be started without liquid in the casing.

The fluid being transferred by the pump lubricates the pump components. Even short periods of running the pump dry could damage the pump. It is recommended that run dry protection be used.

Optional electronic power monitors are available to help protect against run dry.

PUMPING LIQUIDS THAT MAY SOLIDIFY OR CRYSTALLIZE

Add a flush system to the pump's piping to prevent accumulation of material inside the pump. Install water inlet and outlet valves as shown in Figure 1. Refer to the "Operation" section of these instructions for the flush procedure.

Figure 1

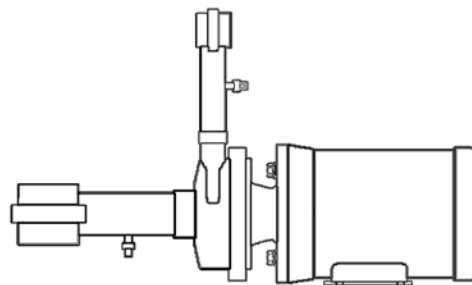

ELECTRICAL CONNECTIONS

1. Perform the motor wiring according to NEC requirements and local electrical codes.
2. Wire the motor for clockwise rotation when facing the fan end of the motor.
3. To verify correct motor rotation
 - a. Install the pump into your system.
 - b. Fully open the suction and the discharge valves.
 - c. Allow fluid to flow into the pump. Do not allow the pump to run dry, as this will cause damage to the seal components.

- d. Jog the motor (allow it to run for only one to two seconds) and observe the rotation of the motor fan. Refer to the directional arrow on the pump if needed.

Note: A pump running backwards will pump but at a greatly reduced flow and pressure.

OPERATION

FLOODED SUCTION SYSTEMS:

1. Fully open the suction and discharge valves.
2. Start the pump and verify liquid is flowing. If there is no liquid flow, refer to the “Troubleshooting” section of these instructions.
3. Adjust the flow rate and pressure by regulating the discharge valve.

CAUTION: Never use the suction valve to adjust the liquid flow. Limiting the suction will result in damage to pump components.

FLUSHING SYSTEMS EQUIPPED WITH FLUSH VALVES

1. Fully close the suction and discharge valves.
2. Connect the water supply to the water inlet valve and connect a drain hose to water outlet valve.
3. Turn on the water supply and open the inlet and outlet valves. Flush the system until the pump has been cleared of any material buildup (usually approximately 5 minutes).
4. Close the water inlet and outlet valves and turn off water supply.

MAINTENANCE

SEAL REPLACEMENT DISASSEMBLY

1. Disconnect power. Remove electrical wiring.
2. Close the suction and the discharge valves. Disconnect the piping. Remove any mounting bolts.
3. For AC6 pumps - To remove the v-clamp (item 2) and the impeller housing (item 1), first apply a thread lubricant to the threaded rod portion of the v-clamp, then remove the nut. Remove the v-clamp, the housing, and the o-ring (item 3).

For AC8 pumps - Remove the 8 housing bolts and all the hardware (items 15,16,17, 18). Remove the impeller housing (item 1) and the o-ring (item 3).

4. Place a screwdriver in the motor fan to prevent rotation and remove the self-sealing bolt (item 6).

Note: Do not reuse the self-sealing bolt.

5. Remove impeller (item 4), rotating seal component, seal spring and seal spring retainer. Discard seal components after removal. (See Figure 2).
6. Remove backhead assembly (item 7) and press out the stationary seal component. Discard stationary seal component after removal.

REASSEMBLY

1. Lubricate the rubber portion of the new stationary seal (item 5) with P-80 (or equivalent) or use soapy water. Do not use petroleum products to lubricate the rubber.

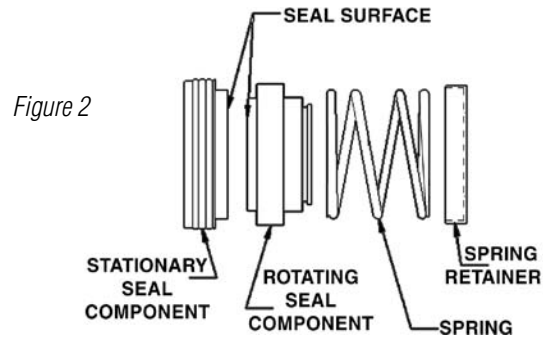

Figure 2

Note: Keep the polished surface of the seal face clean. Use a piece of cardboard to protect the seal while pressing against the stationary face.

2. Press the stationary seal into the seal seat of the backhead assembly so that the seal surface points away from the motor face. Place backhead into motor adapter.
3. Place the spring retainer and seal spring onto the impeller sleeve.
4. Lubricate the inside diameter of the rotating seal component with P-80 (or equivalent) or soapy water and press it over the impeller sleeve (item 4) with the rotating face pointed away from the impeller as shown in Figure 2 (towards the stationary face).
5. Insert key into the motor keyway. Visually determine key location in impeller sleeve. Align keyway slots on motor shaft and impeller sleeve. Slide impeller assembly over the motor shaft. Lubricate o-ring of new self-sealing bolt (item 6) with suitable, compatible lubricant. Insert self-sealing bolt into the eye of the impeller using a 9/16” deep well socket. Insert a screwdriver into the motor fan to prevent motor shaft from rotating. Tighten the bolt to 12-ft lbs.
6. Place impeller housing (item 1) over backhead (item 7) and o-ring (item 3) and make sure discharge is in the correct orientation (usually 12 o'clock).
7. For AC6 pumps – Place the v-clamp (item 2) over the impeller housing, backhead, and the mounting plate (item 14). Make sure the discharge is level and in the correct orientation (see Figure 3). Tighten the nut on the v-clamp. Firmly tap the v-clamp with a mallet in several spots, and then retighten the nut.
For AC8 pumps- Insert the mounting bolts with flat washer (items 15 &16) through the impeller housing (item 1), the backhead (item 7), and the mounting plate (item 14), and tighten with the correct hardware (items 15,17, and 18).
8. Rotate the motor fan by hand and check for impeller rubbing. If the impeller rubs, verify that the self-sealing bolt is properly installed.
9. Reinstall the pump into the system.

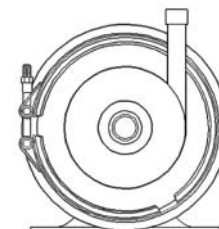
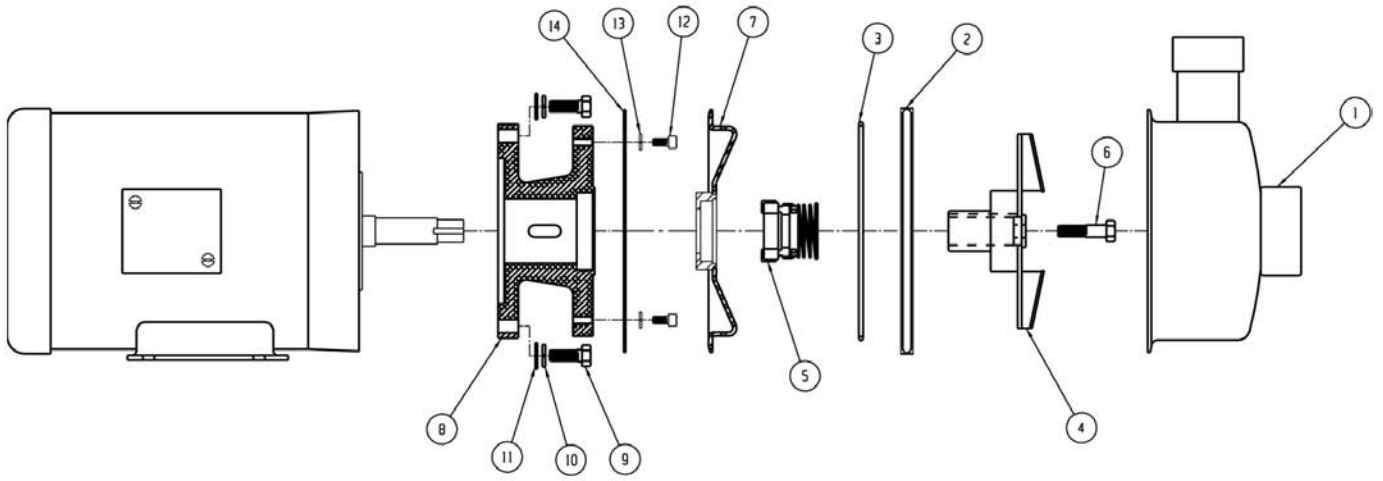
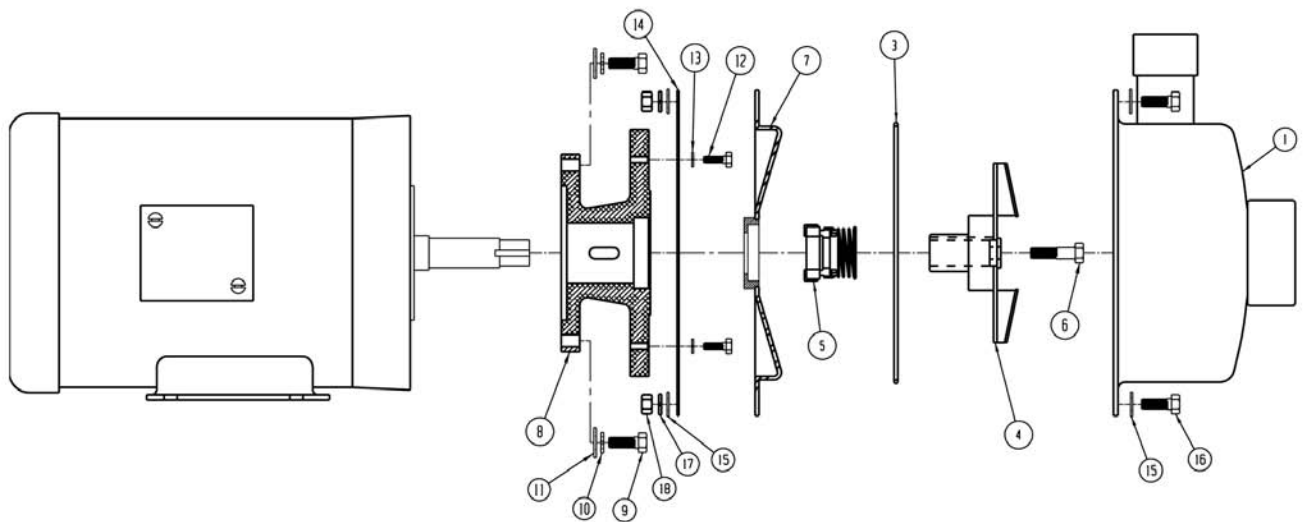

Figure 3

AC 6 EXPLODED VIEW



AC 8 EXPLODED VIEW



Item	Qty	Description	AC6 Part Number		AC8 Part Number	
			AC6SJS	AC6HJS	AC8SJS	AC8HJS
1	1	Impeller Housing				
		AC6SJS 1-1/2 X 1 1/4	A102184-1			
		AC6SJS 2 X 1 1/2	A102184-2			
		AC6HJS 1-1/4 X 3/4 (NPT)		A102232		
		AC6HJS 1-1/2 X 3/4 (BSP)		A102232-1		
		AC8SJS 2 X 1 1/2			A102747-1	
		AC8SJS 2 1/2 X 2			A102747-2	
		AC8HJS 1 1/4 X 3/4				A102528
2	1	V-Clamp	J103090	J103090		
3	1	O-Ring				
		Viton	J103084	J103084	J103087	J103087
		EPDM	J103085	J103085	J103088	J103088
		Teflon	J103257	J103257	J103258	J103258
4	1	Impeller				
		AC6SJS 5 1/4 X 1/4	A102734-6			
		AC6SJS 5 3/4 X 1/4	A102734-7			
		AC6SJS 6 X 1/4	A102734-8			
		AC8SJS 6 1/2 X 1/4			A102734-1	
		AC8SJS 7 X 1/4			A102734-2	
		AC8SJS 7 1/2 X 1/4			A102734-3	
		AC8SJS 8 X 1/4			A102734-9	
		AC8SJS 6 1/2 X 3/8			A102734-4	
		AC8SJS 7 X 3/8			A102734-5	
		AC6/8HJS 6 1/4"		A102735-1		A102735-1
		AC8HJS 7"				A102735-2
		AC8HJS 8"			A102735-3	
5	1	Seal				
		1-1/4" C/R/V	J103493	J103493	J103493	J103493
		1-1/4" C/R/E	J103500	J103500	J103500	J103500
		1-1/4" S/S/V	J103501	J103501	J103501	J103501
		1-1/4" S/S/E	J103502	J103502	J103502	J103502
		1-1/4" C/R/T	J103503	J103503	J103503	J103503
		1-1/2" C/R/K		J103556		
		1-1/2" C/R/E		J103557		
		1-1/2" S/S/V		J103558		
		1-1/2" S/S/E		J103559		
		1-1/2" C/R/K		J103560		
6	1	Self-sealing bolt				
		3/8-16 x 1-1/2" lg. w/Viton	J103495		J103495	
		3/8-16 x 1" lg. w/Viton		J103494		J103494
		M8 x 25mm w/Viton (90 frame)		J103555		
		3/8-16 x 1-1/2" lg. w/EPDM	J103499		J103499	
		3/8-16 x 1" lg. w/EPDM		J103498		J103498
		M8 x 25mm w/EPDM (90 frame)		J103561		
		3/8-16 x 1-1/2" lg w/Teflon	J102823		J102823	
		3/8-16 x 1" lg. w/Teflon		J103582	J103582	
7	1	Backhead	A102677-1	A102677-1	A102677-2	A102677-2
8	1	Motor Adapter				
		AC6SJS	M102051-4			
		AC6SJS Pedestal	M102051-6			
		AC6HJS		M102051-5		
		AC6HJS (90 frame)		M102143		
		AC8SJS (184 JM Frame)			M102051-1	
		AC8SJS (213 JM Frame & Ped)			M102051-2	
		AC8HJS			M102051-3	

Item	Qty	Description	AC6 Part Number		AC8 Part Number	
			AC6SJS	AC6HJS	AC8SJS	AC8HJS
9	4	Hex Head Cap Screw M8 x 25mm (90 frame)		J103662		
		3/8" 145/184 JM Frame	J103118	J103118	J103118	J103118
		1/2" 213 JM Frame			J101858	
10	4	Lock Washer 5/16" 90 frame		J102282		
		3/8" 145/184 JM Frame	J100115	J100115	J100115	J100115
		1/2" 213 JM Frame			J101023	
11	4	Flat Washer 5/16" 90 frame		J101293		
		3/8" 145/184 JM Frame	J100128	J100128	J100128	J100128
		1/2" 213 JM Frame			J101360	
12	8	Socket Head Cap Screw	J103396	J103396	J100320	J100320
13	8	1/4" Lock Washer	J100672	J100672	J100672	J100672
14	1	Mounting Plate	J103389-2	J103389-2	J103857	J103857
15	16	3/8 Flat Washer SST			J100128	J100128
16	8	3/8X1 Hx Hd Cap Screw			J100114	J100114
17	8	3/8 Lock Washers SST			J100115	J100115
18	8	3/8 Hex Nut SST			J100135	J100135

TROUBLESHOOTING

NO OR INSUFFICIENT FLOW:

1. Pump not primed.
2. Closed valve.
3. Viscosity too high.
4. Air leaks in suction piping.
5. Discharge head higher than anticipated.
6. Suction lift too high or insufficient NPSH.
7. Check for clogged suction line.

INSUFFICIENT PRESSURE:

1. Air or gas in liquid.
2. Impeller diameter too small.
3. Discharge head higher than anticipated.
4. Motor speed insufficient (too low) or rotation incorrect.

LOSS OF PRIME:

1. Leaking suction line.
2. Foot valve or suction opening not submerged enough.
3. Foot valve too small or leaking.
4. Air or gas in liquid.
5. Foreign matter in impeller.

EXCESSIVE POWER CONSUMPTION:

1. Head lower than rating. Excessive flow.
2. Specific gravity or viscosity of liquid is too high.

EXCESSIVE VIBRATION:

1. Loose piping or bolts.
2. Pump cavitating from improper suction or feed.

SAFETY PRECAUTIONS FOR ATEX PUMPS

⚠ WARNING: Proper materials of construction must be chosen for the fluid being pumped. Improper material selection could lead to pump failure and leakage. This is the responsibility of the end user.

⚠ WARNING: ATEX pumps must have a power monitor, flow switch, pressure switch or similar device installed to protect against running dry, closed discharge valve, major leaks, and possible sources of ignition due to motor bearing failure. Any of these conditions could lead to a rise in surface temperature of the pump. The device must be set to stop the pump within three seconds of a fault.

⚠ WARNING: The pump must be checked for leaks on a regular basis. If leaks are detected, the pump must be repaired or replaced immediately.

⚠ WARNING: The pump must be cleaned on a regular basis to avoid dust buildup greater than 5mm.

TEMPERATURE CLASSIFICATION

Pump temperature is completely dependent on operating conditions. Pump will transfer heat from the piping system, motor, and fluid.

These items must be considered as a system when assessing an ATEX application.

WARRANTY

Finish Thompson, Inc (manufacturer) warrants this pump product to be free of defects in materials and workmanship for a period of one year from date of purchase by original purchaser. If a warranted defect, which is determined by manufacturer's inspection, occurs within this period, it will be repaired or replaced at the manufacturer's option, provided (1) the product is submitted with proof of purchase date and (2) transportation charges are prepaid to the manufacturer. Liability under this warranty is expressly limited to repairing or replacing the product or parts thereof and is in lieu of any other warranties, either expressed or implied. This warranty does apply only to normal wear of the product or components. This warranty does not apply to products or parts broken due to, in whole or in part, accident, overload, abuse, chemical attack, tampering, or alteration. The warranty does not apply to any other equipment used or purchased in combination with this product. The manufacturer accepts no responsibility for product damage or personal injuries sustained when the product is modified in any way. If this warranty does not apply, the purchaser shall bear all cost for labor, material and transportation.

Manufacturer shall not be liable for incidental or consequential damages including, but not limited to process down time, transportation costs, costs associated with replacement or substitution products, labor costs, product installation or removal costs, or loss of profit. In any and all events, manufacturer's liability shall not exceed the purchase price of the product and/or accessories.

Call our toll free Technical Service Hot Line, 1-800-888-3743, if you have any questions regarding product operation or repair.

For further information, contact Finish Thompson Inc. or your local distributor.

ADDITIONAL INFORMATION

ORDERING SPARE PARTS:

Spare parts can be ordered from your local distributor. Always refer to pump model number to avoid error.

OTHER FTI PRODUCTS:

Drum Transfer Pumps are available in sanitary construction, stainless steel, polypropylene and CPVC. Flows to 40 gpm, discharge heads to 80 feet and viscosities to 15,000 cps.

Portable Mixers for turbine mixing and blending handle viscosities to 1,000 cps with gentle, non-vortex circulation. Available in 316 stainless steel construction.

Sealed Centrifugal Pumps in GF polypropylene and CF PVDF come with a wide variety of sealing materials. Flows to 250 gpm, discharge heads to 130 feet and temperatures to 200°F (93°C).

Sealless Mag Drive Centrifugal Pumps in GF polypropylene and CF PVDF. Flows to 250 gpm and discharge heads to 135 feet. Handles temperatures up to 220°F and have 30-minute run-dry capability. Mounts to standard frame motors.



FINISH THOMPSON INC.

927 Greengarden Road • Erie, PA 16501-1591 U.S.A.

Ph: 814-455-4478 • Fax: 814-455-8518

Email: fti@finishthompson.com - www.finishthompson.com

Part No. J103532, Rev. 9

Literature ID No. FT00-793G, 10-31-08

